

**Din : 46235**

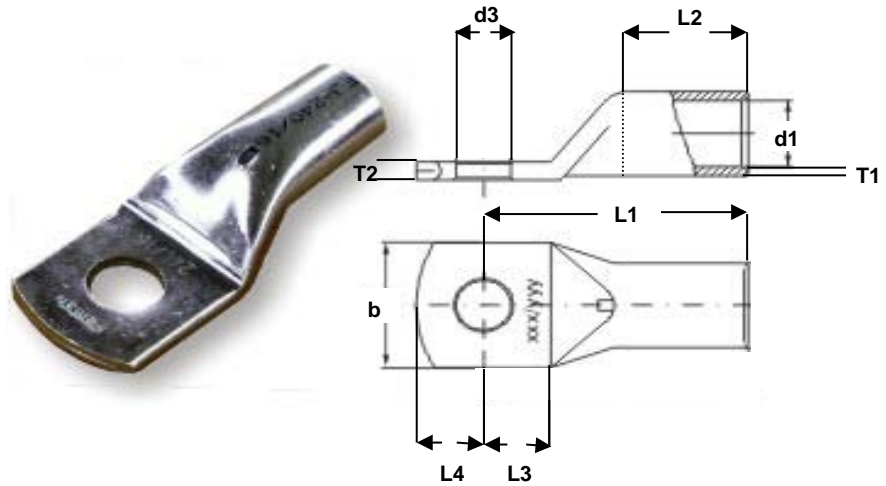

Cross Section mm <sup>2</sup>	Bolt Size	L1 mm	L2 mm	L3 mm	L4 mm	d1 mm	T1 mm	d3 mm	b mm	T2 mm
6	M 6	24+2	min10	min8	10.5-3	3.8+/-0.3	0.6+/-0.5	6.4	8.5+/-1	1.5+/-0.5
10	M 6	27+2	min10	min8	10.5-3	4.5+/-0.3	1+/-0.5	6.4	9+/-1	1.5+/-0.5
16	M 8	36+2	min20	min10	13-3	5.5+/-0.3	1+/-0.5	8.4	13+/-1	2.5+/-0.5
25	M 8	38+2	min20	min10	13-3	7+/-0.3	1+/-0.5	8.4	16+/-1	3+/-0.5
35	M 12	42+2	min20	min13	16-3	8.2+/-0.3	1+/-0.5	13	21+/-1	3.5+/-0.5
50	M 12	52+2	min28	min13	16-3	10+/-0.3	1+/-0.5	13	24+/-1	4+/-0.5
70	M 12	55+2	min28	min13	16-3	11.5+/-0.3	2+/-0.5	13	24+/-1	4.5+/-0.5
95	M 12	65+2	min35	min13	16-3	13.5+/-0.3	2+/-0.5	13	28+/-2	5+/-0.5
120	M 12	70+2	min35	min13	16-3	15.5+/-0.3	2+/-0.5	13	32+/-2	5.5+/-0.5
150	M 12	78+2	min35	min13	16-3	17+/-0.3	2+/-0.5	13	34+/-2	6+/-0.5
185	M 12	82+2	min40	min13	16-3	19+/-0.4	2+/-0.5	13	37+/-2	6+/-0.5
240	M 16	92+2	min40	min16	19-3	21.5+/-0.4	2+/-0.5	17	42+/-2	6.5+/-0.5
300	M 16	100+2	min50	min16	19-3	24.5+/-0.4	2+/-0.5	17	48+/-2	7+/-0.5
400	M 16	115+2	min70	min16	25-3	27.5+/-0.4	3+/-0.5	17	55+/-2	10+/-1
500	M 20	125+2	min70	min20	25-3	29+/-0.5	3.5+/-1.5	21	60+/-5	10+/-1
630	M 20	135+2	min80	min20	25-3	34+/-0.5	3.5+/-1.5	21	60+/-5	10+/-1
800	M 20	165+2	min100	min20	25-3	39.5+/-0.5	4+/-1.5	21	75+/-5	12+/-1
1000	M 20	165+2	min100	min20	25-3	43.5+/-0.5	4+/-1.5	21	85+/-5	14+/-1